

European Exascale System Interconnect & Storage

www.exanest.eu

Peter Hopton (peter.hopton@iceotope.com)

Iceotope, UK

The Foundations For ExaScale

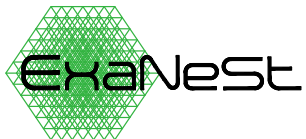

What ExaNeSt is about

- ARMv8, UNIMEM Partitioned Global Address Space (PGAS)
 - low energy compute
 - low overhead communicate
 - FPGA-assisted acceleration
 - working closely with *ExaNoDe*, *EcoScale*, (& EuroServer)
- **Network**: *unified* compute & storage, low latency
- **Storage**: distributed, *in-node* non-volatile memories
- Real ***Applications***: Scientific, Engineering, Data Analytics
- Data Centre ***Infrastructure*** (Power and Cooling): Total Liquid Cooling
- ***Prototype***: 1K cores, 16GBytes DDR4 per FPGA

The ExaNeSt Consortium



Network

Interconnection Network

- Now: Simulations, Studies:
 - at the Packet/flit level, for protocol behavior and interactions (using INSEE and Omnet+);
 - Traffic Inputs: Synthetic models, real App Traces, or running App's.
- Later: Experiments on real Prototype running real App's
- Packaging & interconnect considered in tandem
 - Hierarchical interconnect
- Design Goals:
 - unified network for compute & storage
 - flow prioritization: heavy / storage versus short / sync (compute)
 - throttle congestive flows at network edges
 - resiliency: error detect/correct, monitor links, multipath routing
 - Zero-copy, user-level RDMA
 - Global address space
 - all-optical proof-of-concept TOR switch using 2x2/4x4 building blocks

Storage

Storage: current Design work

*Global Storage Layer +
+ per-job SSD/NVM on-demand Parallel Cache Layer*

- Based on the BeeGFS parallel filesystem (open source), with caching and replication extensions
- Low-latency memory-mapped storage access path in Linux
- Virtualization: RDMA from within VM's; MPI remoting
- Acceleration for Host-to-VM and VM-to-VM interactions

Applications

Applications, Traces

Main Applications:

- *Material science*: LAMMPS
- *Climate change*: REGCM
- *Engineering CFD*: openFoam, SailFish
- *Astrophysics*:
 - *Large-scale high-resolution simulations of cosmic formation and evolution*
 - Gadget, Pinocchio, Changa, Swift
- *Neuroscience – brain simulation*: DPSNN
- *High Energy Physics*
 - Lattice Quantum Chromodynamics simulations - LQCD
- *Data Analytics*: MonetDB
- Porting selected App's to ARM

Infrastructure

Power

- 48V DC to PoL Converter on Daughter Board
- 3 Phase 415V to 48V DC Liquid Cooled Power Conversion
- 48V DC Power Distribution
- Ambition to integrate renewable energy on-site generation and energy storage at DC to remove conversion cycles and give “green power” (*Separate Project*)

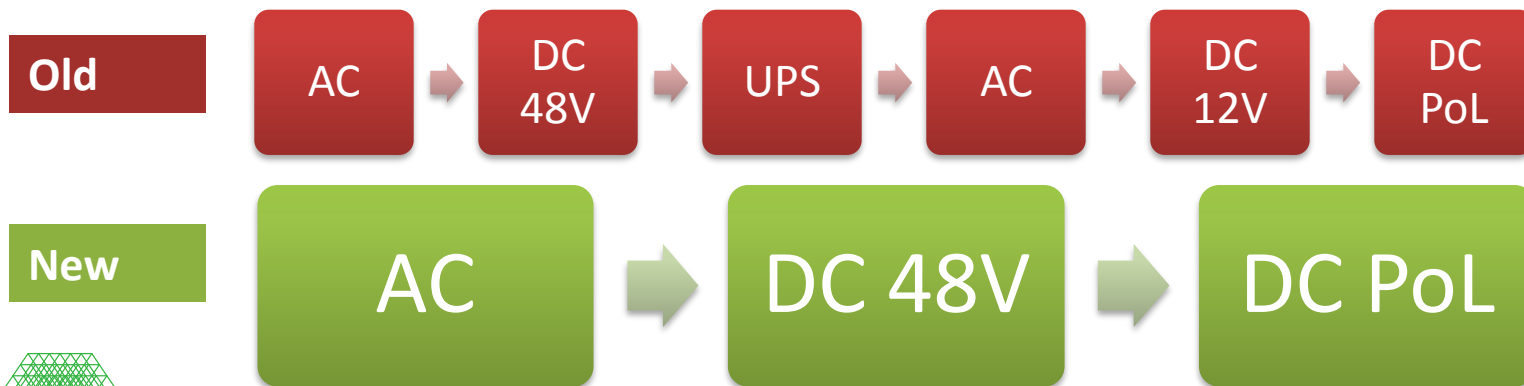

Cooling

Combination of 3 Different Patented Cooling Technologies

- Immersion
 - Natural Convection “Cells”
 - Forced Convection “Fountains”
- Conduction
- Total Liquid Cooling
- Zero Airflow
- Potential for High Temperatures and Heat Capture

Prototypes

Our Nodes

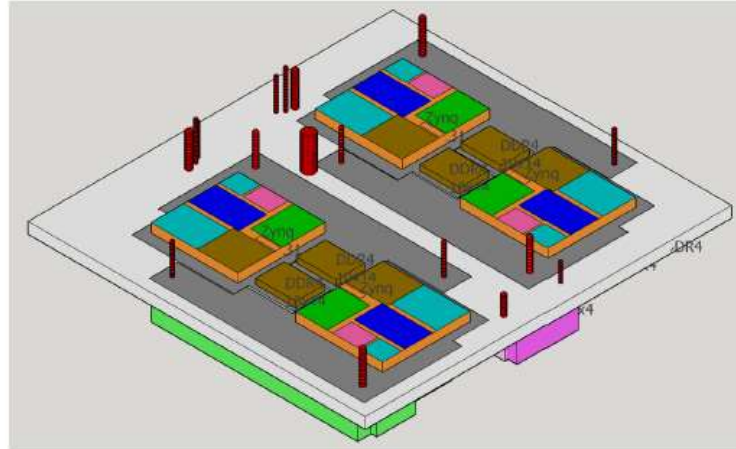

Figure 2: Iso view

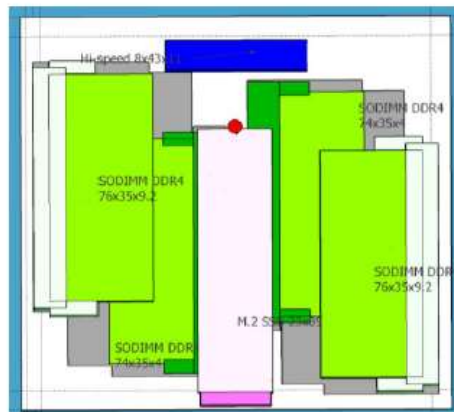

Figure 3: Bottom view

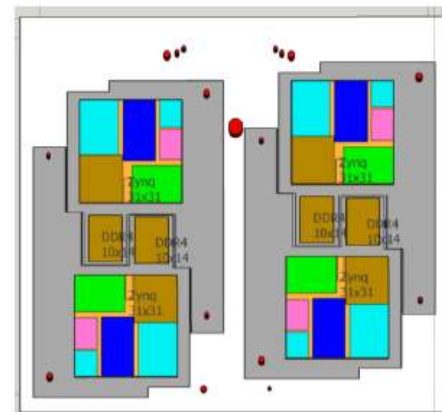
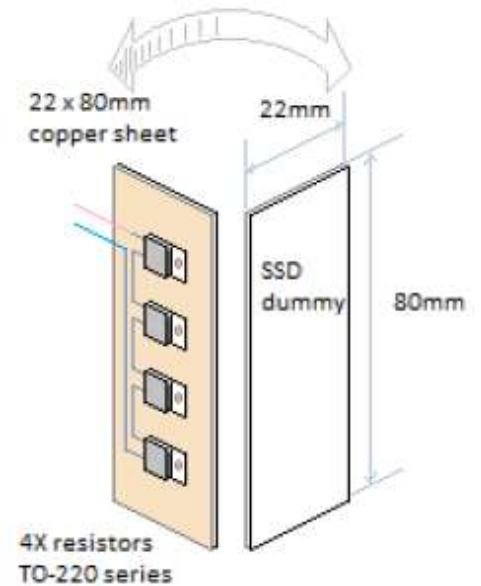
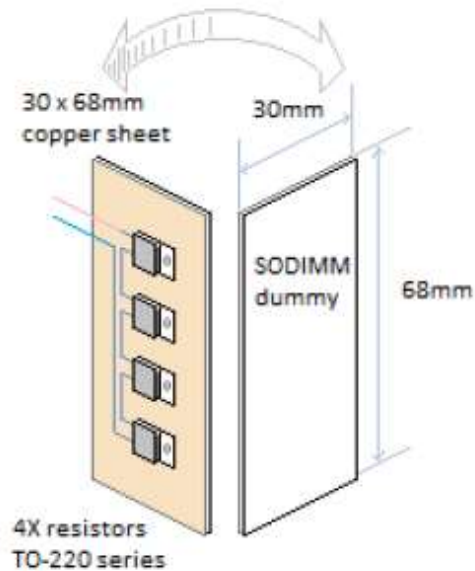
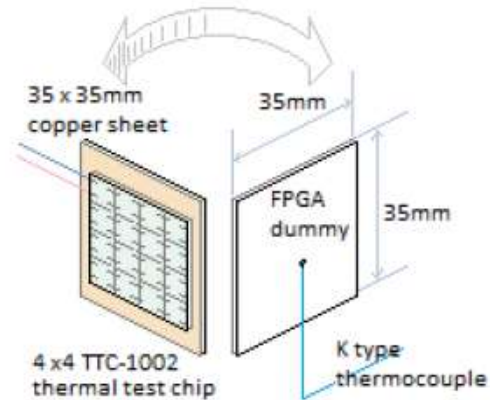
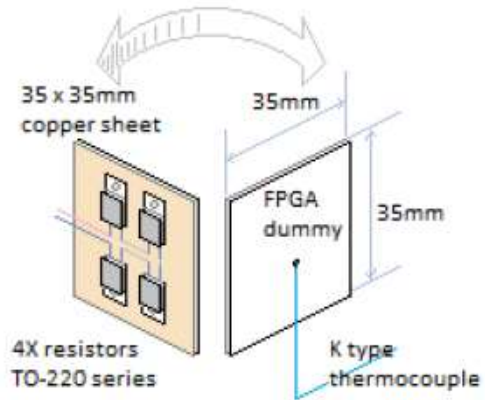
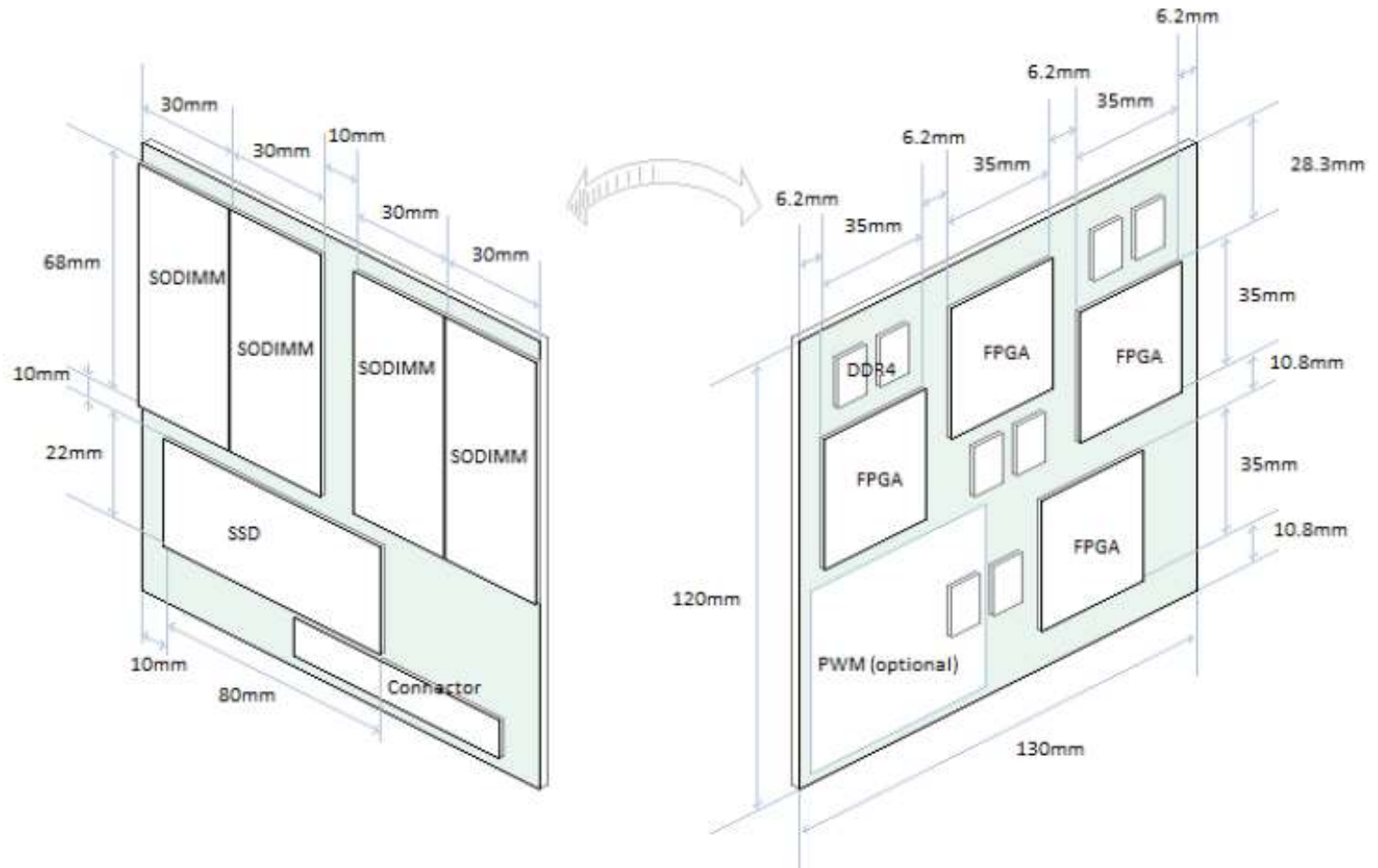

Figure 4: Top view

Thermal Proxies



Thermal Proxies



The 1st Major ExaNeSt Prototype (2017)

- Using Xilinx Zynq UltraScale+ FPGAs:
 - Quad-core 64-bit ARM A53 per FPGA
 - Cache-coherent low-latency I/O port
- On 120×130 mm² Daughter Boards
 - 4 FPGA's
 - 0.5 to 1 TBy SSD
 - 10× 16Gb/s I/O's
- 1st Prototype
 - Up to 8 DB's per Blade, 9 Blades
- In Early Test Now
 - First deployment = within 2017



The 2nd Major ExaNeSt Prototype (2018)

- Same FPGAs, Same Quad FPGA Daughter Board
- 16 DB's per Blade, 2 Blades per u, 3.2kW per u
- Hot Water Cooling (>50C), Heat Capture Functions
- 100kW cabinets, 1.0x PUE, >0.9 ERF Potential
- DC Power Distribution
- Potential for High Density Data Centres or Modular Facilities:

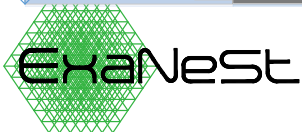
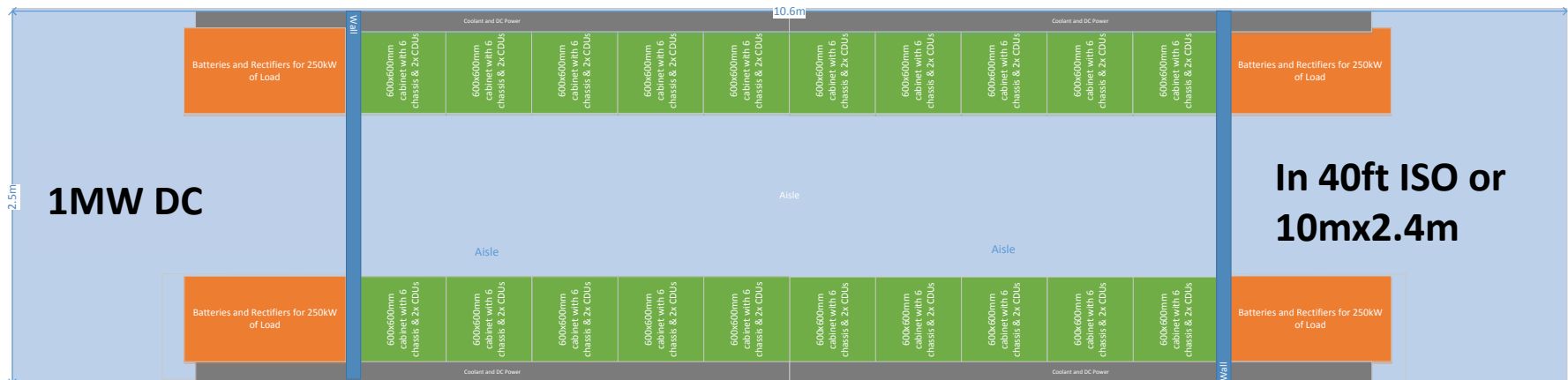

What ExaneSt offers to the Ecosystem

- Use of the Prototypes by ExaNoDe and EcoScale
- Use of the Prototype by the Ecosystem (2018 onwards)
- HPC technology components (2018 onwards):
 - ARM/Unimem
 - Fine-tuned Applications
 - The Ultra-Dense Data Centre for Scaling HPC
 - Packaging & Cooling
 - Distributed NVM / Storage
 - Interconnects
 - DB compute-node prototype

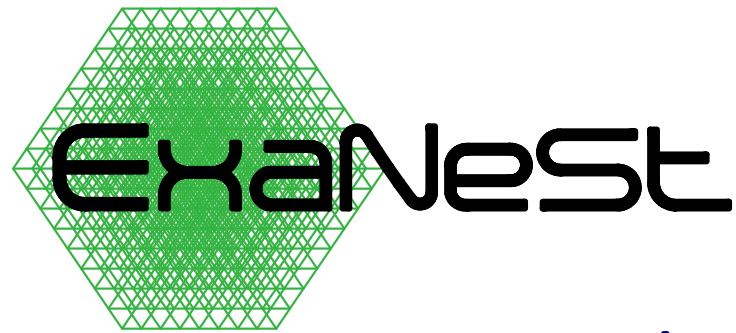

European Exascale System Interconnect & Storage

- Interconnection Network
- In-node Storage
- Data Centre Infrastructure
- Advanced Cooling & Power
- Real Applications

www.exanest.eu Project Coordinator:

Prof. Manolis Katevenis (kateveni@ics.forth.gr)

